

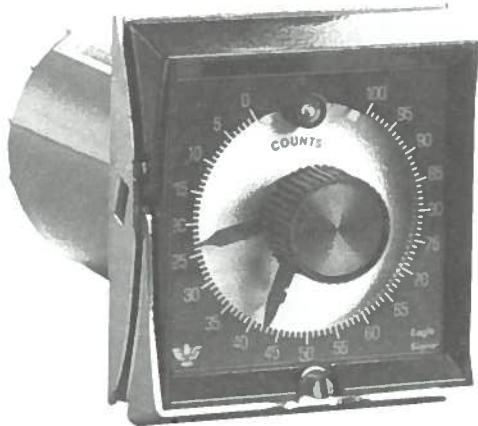

HZ170 SERIES CYCL-FLEX® COUNTER HZ170/172 - Model 11 HZ171 - Model 8



The HZ170 Series is an electromechanical counter housed in the standard CYCL-FLEX® case. The unit is available in three count ranges, 12, 40, and 100. The count set point is adjustable by a knob on the front of the unit.

All three count ranges use a solenoid operated pawl feed count motor and an electromechanical clutch.

A progress pointer, indicating the count progression, advances clockwise, from set point to zero.

Output sequences are controlled by two sets of SPDT instantaneous contacts and two delayed SPDT switches. The delayed switches transfer at count out.

The instantaneous and delayed contacts may be interconnected to supply output sequences shown elsewhere in this bulletin.

As an option, the HZ170 is available with a reverse action clutch. Units with reverse action clutch do not reset on power failure.

OPERATION

The HZ170 Series Counter is an impulse motor driven unit with standard or reverse clutch operation.

When power is applied to the clutch terminals on standard units, the clutch engages and instantaneous contacts transfer, enabling the counter to receive and register counts. A 40ms pulse to the count motor will register a count by moving the count progress pointer toward the zero point on the dial. When the progress pointer reaches zero the unit is counted out and a set of delayed switches transfer. Additional counts will not be registered until the unit is reset. Removal of power from the clutch terminals resets the counter.

Units with 40 count and 100 count ranges have two delayed action switches. By adjustment of set screws on the switch trip lever, a transfer differential between the two switches can be obtained. The 40 count range switch differential can be adjusted for one count early transfer before count out. The 100 count range differential is two counts.

On reverse action clutch operation, removal of power from the clutch terminals enables the counter to receive counts.

SPECIFICATIONS

Count Ranges

Symbol	Count Range	Minimum Setting
0	2 - 100	2
1	1 - 12	1
2	1 - 40	1

Count Speed

500 counts per minute maximum

Accuracy

100%

Reset Time

500 ms at maximum setting

Input Requirements

Stepping motor - 40 ms "ON" time; 80 ms "OFF" time

Clutch coil - 50 ms Pull in

Voltage and Frequency

120 VAC (+10 -15%) 50/60Hz

240 VAC (+10 -15%) 50/60Hz

Burden

Stepping motor - 26 V.A., Inrush

Clutch coil - 16 V.A. Inrush Maintained, 10.5 V.A.

Output Rating

10 Amperes 120 Volt 50/60Hz

5 Amperes 240 Volt 50/60Hz

Operating Temperature

0° to 140°F (-18° to 60°C)

Enclosures and Accessories

See Bulletin 2500

Laboratory Testing

U.L. Recognition E-44416

C.S.A. Certification LR-26861

Eagle Signal Controls

A Mark IV Industries Company
8004 Cameron Road, Austin, Texas 78753 U.S.A.

COUNT CONTROL



COUNTER OPERATION

INSTANTANEOUS CONTACTS 6-7 A-C are open and 6-8 A-B closed when the counter is in reset. Contacts 6-8 A-B are open and 6-7 A-C closed when the counter is in the counting or counted out position.

DELAYED CONTACTS 4-3 and 9-10 close, 4-5 and 9-11 open when the red progress pointer reaches zero. Contacts 4-5 and 9-11 close, 4-3 and 9-10 open when the counter is reset.

NEON PILOT LIGHT is built into dial to indicate counter clutch coil is energized.

SWITCH	RESET	COUNTING	COUNT OUT
6 - 7	O	X	X
6 - 8	X	O	O
A - C	O	X	X
A - B	X	O	O
4 - 5	X	X	O
4 - 3	O	O	X
9 - 11*	X	X	O
9 - 10*	O	O	X
HZ170A6 Clutch Coil	Deener.	Ener.	Ener
HZ170A601 Clutch Coil	Ener.	Deener.	Deener.

Switches trip to count-out position on last deenergized stroke of count solenoid.

X — Switch Closed O — Switch Open

SCHEMATIC DIAGRAM

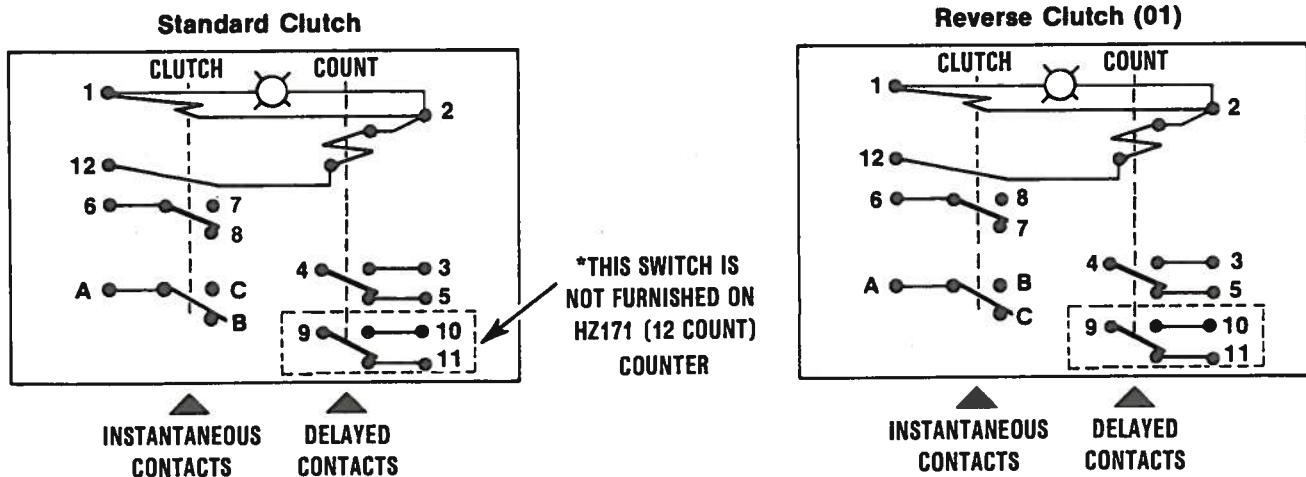

NOTE: Counter has a positive toothed clutch. Setting adjustments must be made with clutch released.



WIRING DIAGRAMS

Bold Lines are Internal Wiring

STANDARD HZ170 & HZ172 CYCL-FLEX® COUNTER

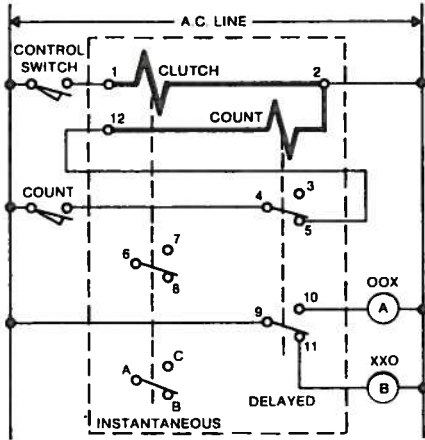

Figure 1

Sustained Control Switch. Close to Start, Open to Reset — Simple delayed closing and opening of load circuits.

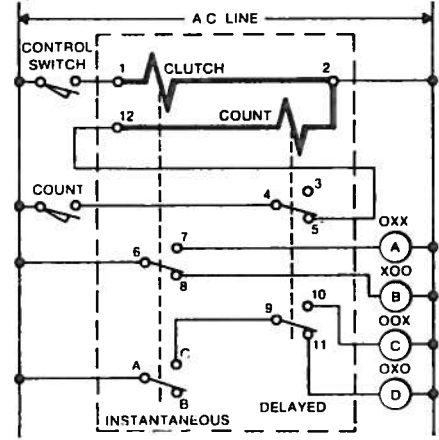

Figure 2

Sustained Control Switch. Close to Start, Open to Reset — Additional load circuit operations.

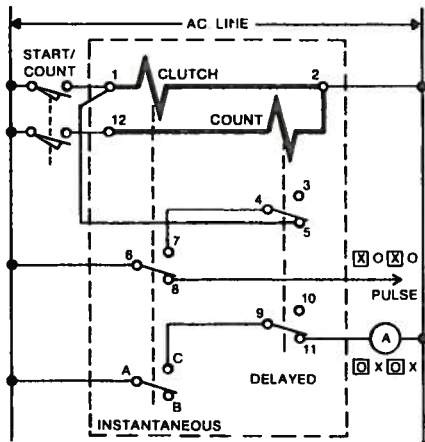

Figure 3

Automatic Repeat Cycle — Started by incoming count switch. Resets automatically. Provides a pulse to start a timer or other device every pre-selected number of counts.

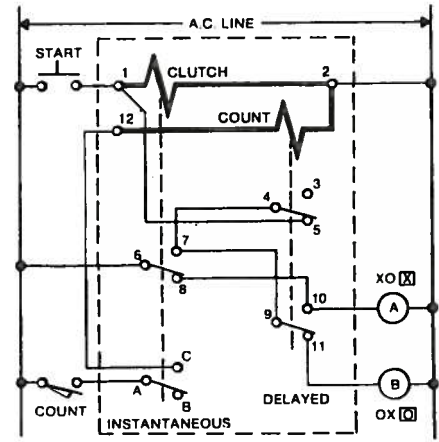

Figure 4

Momentary Start — Close to start, resets automatically.

REVERSE START HZ170-01 SERIES CYCL-FLEX® COUNTER

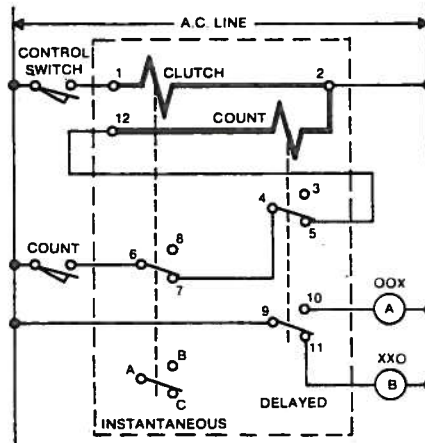

Figure 5

Open Control Switch to Start — Close for one-half second minimum to reset. Simple delayed closing and opening of load circuits.

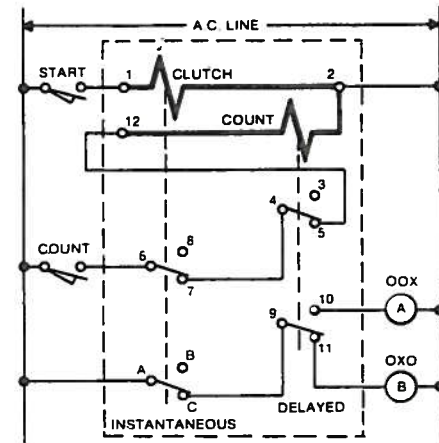
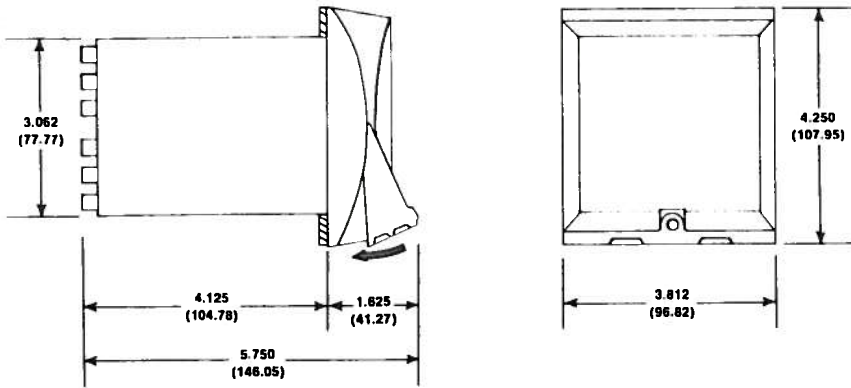

Figure 6

Open Control Switch to Start — Close for one-half second minimum to reset. Additional load circuit operations.



MOUNTING DIMENSIONS



TERMINALS AND WIRING DIAGRAM ON REAR OF CASE

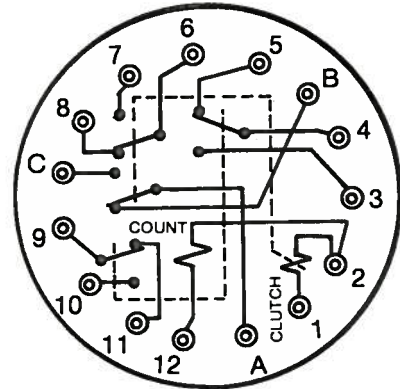

DRILL AND TAP FOUR HOLES FOR 8-32 SCREWS (INCLUDED W/UNIT)

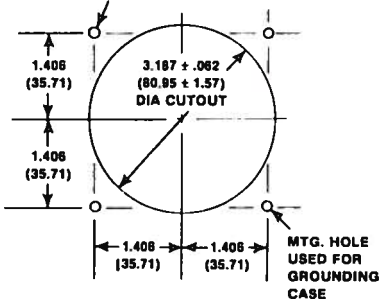

MINIMUM SPACING

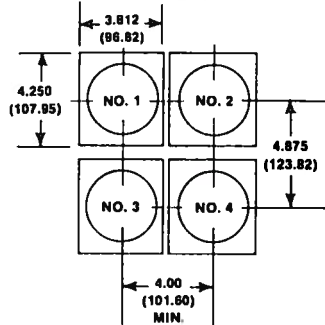

ORDERING INFORMATION

BASIC UNIT

SYMBOL	COUNT RANGE
0	2 - 100
1	1 - 12
2	1 - 40

VOLTAGE/FREQUENCY

SYMBOL	VOLTAGE & HZ
A6	120 VAC 50/60 Hz
B6	240 VAC 50/60 Hz

HZ17 0 A6 01

FEATURES

SYMBOL	DESCRIPTION
01	Reverse Clutch
02	Revised for Mounting in NEMA VII Explosion Proof Enclosure HN384
05	Chrome Plated Bezel
07	Dial Lock
15	Stainless Steel Handle and Housing Plate
92	Enclosed in HN384 Explosion-Proof Cabinet