

BILL OF MATERIAL (CS BODY/416SS TRIM)					BILL OF MATERIAL (316SS BODY/316SS TRIM)					BILL OF MATERIAL (ALL 316SS)							
NO.	NAME OF PART	QTY.	MATERIAL	PART NO.	SPECIFICATION	NO.	NAME OF PART	QTY.	MATERIAL	PART NO.	SPECIFICATION	NO.	NAME OF PART	QTY.	MATERIAL	PART NO.	SPECIFICATION
1	BODY, VALVE	1	LOW TEMP CS	PER ORDER	A350 GR.LF2	1	BODY, VALVE	1	316/316L SS	PER ORDER	A182 GR.F316/316L	1	BODY, VALVE	1	316/316L SS	PER ORDER	A182 GR.F316/316L
2	SEAT	1	416SS	P125 U3	QQ-S-763	2	SEAT	1	316/316L SS	P125 T2	A479	2	SEAT	1	316/316L SS	P125 T2	A479
3	STEM	1	416SS	V21764 U3	QQ-S-763	3	STEM	1	316/316L SS	V21764 T2	A479	3	STEM	1	316/316L SS	V21764 T2	A479
4	TAILPIECE, TANK CONNECTION	1	LOW TEMP CS	PER ORDER	A350 GR.LF2	4	TAILPIECE, TANK CONNECTION	1	316/316L SS*	PER ORDER		4	TAILPIECE, TANK CONNECTION	1	316/316L SS*	PER ORDER	
5	NUT, TAILPIECE	1	LOW TEMP CS	PER ORDER	A350 GR.LF2	5	NUT, TAILPIECE	1	LOW TEMP CS	PER ORDER	A350 GR.LF2	5	NUT, TAILPIECE	1	316/316L SS	PER ORDER	A276 GR.F316/316L
6	GASKET, TAILPIECE (SEE NOTE 8)	2	PER ORDER	PER ORDER		6	GASKET, TAILPIECE (SEE NOTE 8)	2	PER ORDER	PER ORDER		6	GASKET, TAILPIECE (SEE NOTE 8)	2	PER ORDER	PER ORDER	
7	BONNET, PACKING	1	LOW TEMP CS	P8590 A32	A350 GR.LF2	7	BONNET, PACKING	1	316/316L SS	P8590 TL2	A182 GR.F316/316L	7	BONNET, PACKING	1	316/316L SS	P8590 TL2	A276 GR.F316/316L
8	NUT, BONNET	1	LOW TEMP CS	P70 6 A32	A350 GR.LF2	8	NUT, BONNET	1	LOW TEMP CS	P70 6 A32	A350 GR.LF2	8	NUT, BONNET	1	316/316L SS	P70 6 T2	A276 GR.F316/316L
9	WASHER, PACKING	1	LOW TEMP CS	P8589 A32	A350 GR.LF2	9	WASHER, PACKING	1	316/316L SS	P8589 TL2	A479	9	WASHER, PACKING	1	316/316L SS	P8589 TL2	A479
10	WASHER, PACKING	1	LOW TEMP CS	P8591 A32	A350 GR.LF2	10	WASHER, PACKING	1	316/316L SS	P8591 TL2	A479	10	WASHER, PACKING	1	316/316L SS	P8591 TL2	A479
11	PACKING, LOW EMISSIONS	1	GRAPHITE	G289		11	PACKING, LOW EMISSIONS	1	GRAPHITE	G289		11	PACKING, LOW EMISSIONS	1	GRAPHITE	G289	
12	BALL CHECK	1	440SS	P1 I		12	BALL CHECK	1	316SS	P1 T2	QQ-S-763	12	BALL CHECK	1	316SS	P1 T2	QQ-S-763
13	STOP, BALL CHECK	1	316SS	V13113 T		13	STOP, BALL CHECK	1	316SS	V13113 T		13	STOP, BALL CHECK	1	316SS	V13113 T	
14	HANDWHEEL	1	CARBON STEEL	PD325 D1		14	HANDWHEEL	1	CARBON STEEL	PD325 D1		14	HANDWHEEL	1	316SS	PD325 T11	
15	NUT, STEM	1	CARBON STEEL	P78 6 A12	A563	15	NUT, STEM	1	CARBON STEEL	P78 6 A12	A563	15	NUT, STEM	1	316/316L SS	P78 6 T	
16	TAG, RATING	1	304SS	V22038 2		16	TAG, RATING	1	304SS	V22038 2		16	TAG, RATING	1	304SS	V22038 2	
17	TAG, API 624 (NOT SHOWN)	1	ALUMINUM	V21969		17	TAG, API 624 (NOT SHOWN)	1	ALUMINUM	V21969		17	TAG, API 624 (NOT SHOWN)	1	ALUMINUM	V21969	
18	NUT, TAILPIECE	1	LOW TEMP CS	PER ORDER	A350 GR.LF2	18	NUT, TAILPIECE	1	LOW TEMP CS	PER ORDER	A350 GR.LF2	18	NUT, TAILPIECE	1	316/316L SS	PER ORDER	A276 GR.F316/316L
19	TAILPIECE, GAGE CONNECTION	1	LOW TEMP CS	PER ORDER	A350 GR.LF2	19	TAILPIECE, GAGE CONNECTION	1	316/316L SS*	PER ORDER		19	TAILPIECE, GAGE CONNECTION	1	316/316L SS*	PER ORDER	

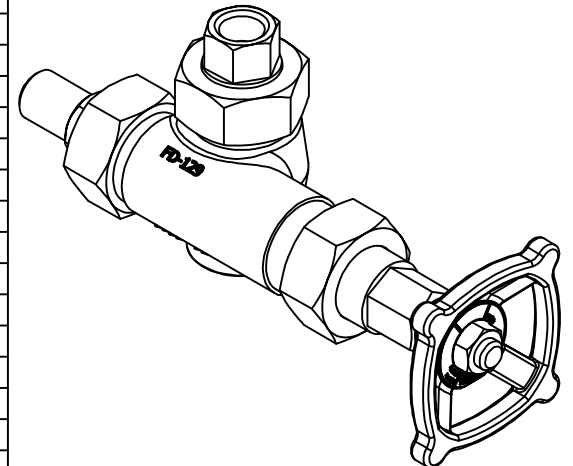

UNION TANK CONNECTION ("A" DIMENSION)								
1/2" MNPT (OR MSW)	1/2" FNPT (OR FSW)	1/2" MNPT SPH (OR MSW)	1/2" FNPT SPH (OR FSW)	3/4" MNPT	3/4" MSW	3/4" FNPT	3/4" MNPT SPH (OR MSW)	1" MNPT (OR MSW)
3.688	2.813	4.313	3.438	3.688	4.500	2.813	4.313	4.125
[94]	[71]	[110]	[87]	[94]	[114]	[71]	[110]	[105]

  

UNION GAGE CONNECTION ("B" DIMENSION)								
1/2" MNPT (OR MSW)	1/2" FNPT (OR FSW)	1/2" MNPT SPH (OR MSW)	1/2" FNPT SPH (OR FSW)	3/4" MNPT	3/4" MSW	3/4" FNPT	3/4" MNPT SPH (OR MSW)	1" MNPT (OR MSW)
3.563	2.688	4.188	3.313	3.563	3.563	2.688	4.188	4.000
[91]	[68]	[106]	[84]	[91]	[91]	[68]	[106]	[102]

\*17-4PHSS FOR SPHERICAL TAILPIECES

\*17-4PHSS FOR SPHERICAL TAILPIECES

VENT/DRAIN CONNECTION  
1/2" FNPT (OR FSW) ONLY

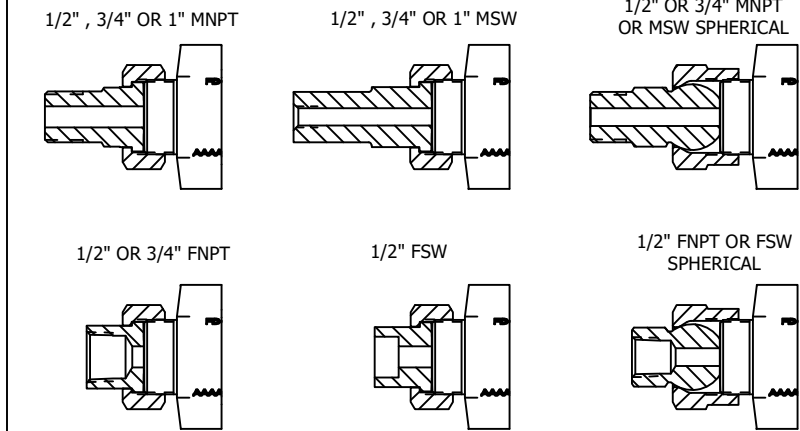

TANK CONNECTION  
(3/4" FSW UNION CONNECTION NOT AVAILABLE AS STANDARD)

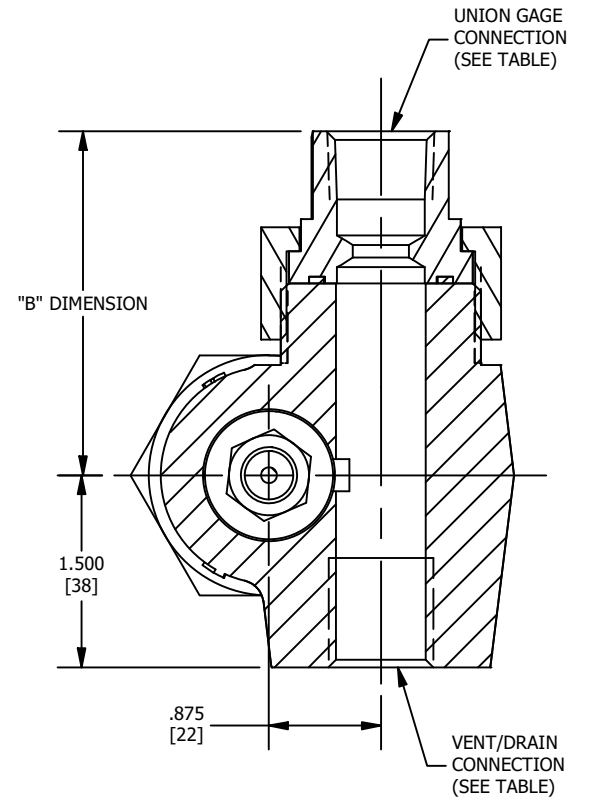
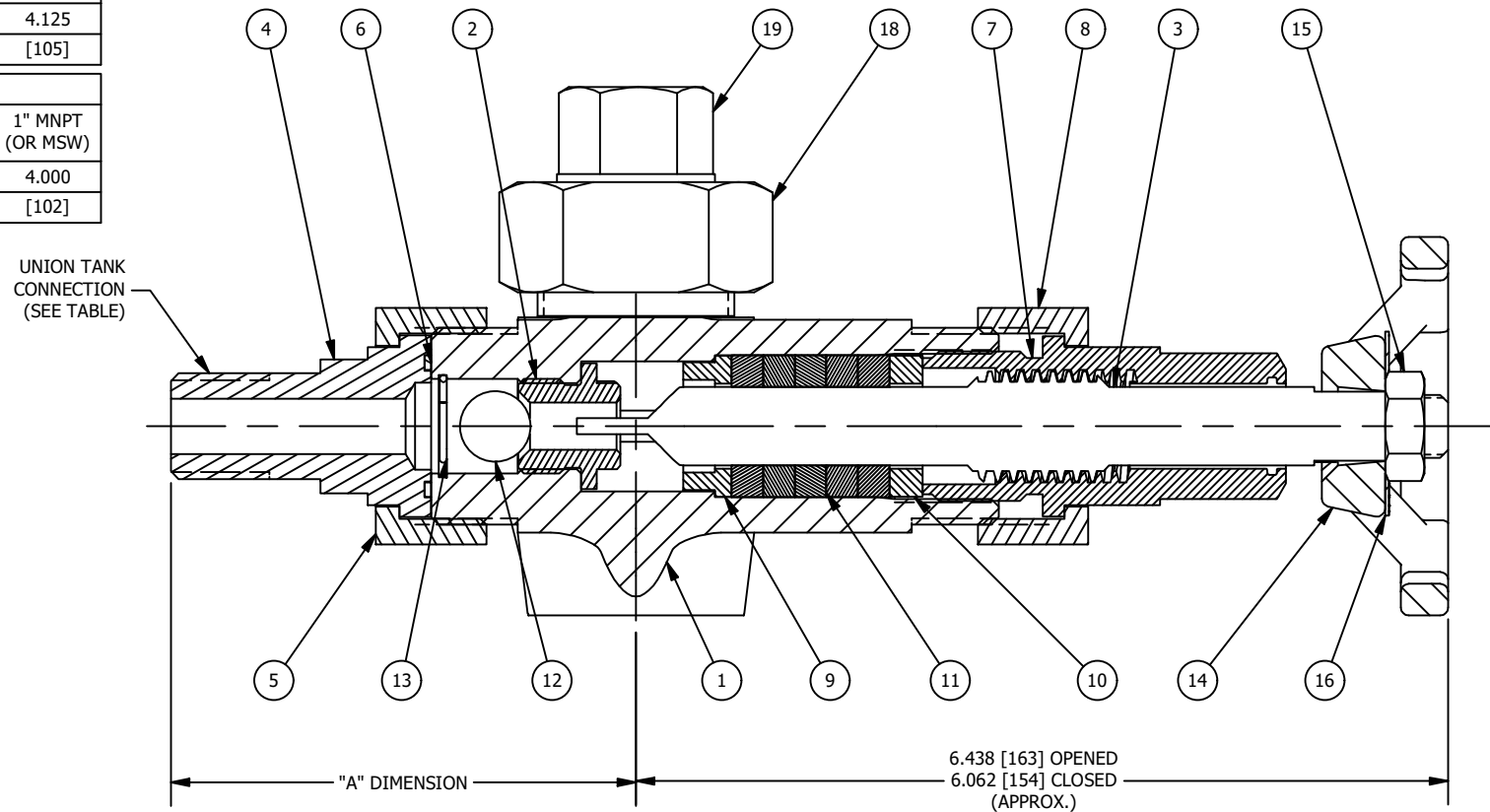

- NOTES:
- DIMENSIONS IN INCHES W/ mm EQUIVALENTS IN BRACKETS
  - TOP AND BOTTOM VALVES SAME EXCEPT OPPOSITE HANDING (I.E., MIRROR IMAGES) (BOTTOM LEFT HAND VALVE SHOWN)
  - VALVE RATING - CARBON STEEL & 316SS:  
4000 PSI @ 100°F, 1308 PSI @ 800°F  
(281 KG/CM<sup>2</sup> @ 38°C, 92 KG/CM<sup>2</sup> @ 427°C)
  - SEE TABLES FOR AVAILABLE STANDARD CONNECTIONS
  - REFER TO THE FOLLOWING (FOR):  
• CATALOG BULLETIN J100.51 (ADDITIONAL INFORMATION)  
• IOM BULLETIN J500.13 (INSTRUCTIONS)
  - VALVE "TRIM" = SEAT, STEM & BALL CHECK
  - CONSULT FACTORY FOR ALTERNATE MATERIAL OPTIONS
  - FOR STRAIGHT UNION TAILPIECES USE V9864 1 (MATERIAL: GRAPHITE/304SS)  
FOR SPHERICAL UNION TAILPIECES USE V22244 (MATERIAL: GORE GR EPTFE)

REV	DATE	REVISION	BY
1	11/14/2022	UPDATE HANDWHEEL MATERIAL ON ALL 316SS BOM TO 316SS	CMN
0	11/11/2019	NEW RELEASE	RMW

MANUFACTURED BY  
  
 16633 FOLTZ PARKWAY  
 STRONGSVILLE, OH 44149 USA  
 (440) 572-1500 | www.clarkreliance.com  
 © Clark-Reliance® LLC. All Rights Reserved.

#67LE OFFSET VALVE (PLAIN-CLOSING)  
 UNION TANK CONNECTION  
 UNION GAGE CONNECTION

JERGUSON®

DRAWN: RMW	DRAWING NO.: 67LE	REV.: 1
CHECKED: SH		
DATE: 11/11/2019		
CDC: 1 : PER CDC 22-454 : CMN : 11/14/2022		
MATERIAL: SEE BOM		
PART NUMBER: 67LE		

TOLERANCES (U.O.M.):  
 3 Decimal Places: ± .030"  
 2 Decimal Places: ± .060"  
 Fractions: ± .030"  
 Machined Holes: ± .005"  
 Angles: ± 1°  
 Finish Marks: ≤ 125 RMS  
 (See PES-004 for details.)